

<b>MANUFACTURER</b> <i>Produttore</i>	Phoenix Prime Focus, Italy	
<b>MODEL NO.</b> <i>Model</i>	Tandoor TR850	
<b>DESCRIPTION</b> <i>Descrizione</i>	Tandoor Oven - Round shaped exterior finish ( painted finish as standard ) <i>Forno Tandoori - Struttura rotonda esterna ( Verniciatura inclusa )</i>	
<b>PURPOSE</b> <i>Scopo</i>	Indian Tandoor oven for cooking naan breads, skewered meats and other dishes <i>Forno indiano Tandoori per la cottura di pane Naan, spiedini di carne e altri piatti</i>	
<b>FUEL OPTIONS</b> <i>Opzioni di riscaldamento</i>	Solid fuel ( charcoal or wood ) - Gas - Electric <i>Carbone o legna - Gas - Elettrico</i>	
<b>FUEL REQUIREMENTS</b> <i>Requisiti per l'alimentazione</i>	Solid fuel ( charcoal or wood ) <i>Combustibile solido ( carbone o legna )</i>	
<b>GAS REQUIREMENTS</b> <i>Requisiti per il Gas</i>	70mJ ( 66.347 BTU - 19.4KW )	
<b>ELECTRICAL REQUIREMENTS</b> <i>Requisiti elettrici</i>	3PH - 380/415 V - 11KW	
<b>EXHAUST REQUIREMENTS</b> <i>Requisiti di scarico fumi</i>	Under Exhaust Canopy/Hood ( by Others ) <i>Sotto cappa aspirante ( non inclusa )</i>	
<b>EXTERNAL DIMENSIONS</b> <i>Dimensioni esterne</i>	850 Diameter x 900(H) mm	Weight Approx / Peso 725Kg
<b>INTERNAL DIMENSIONS</b> <i>Dimensioni interne</i>	530mm Diameter cooking pot 530mm Diametro della bolla di cottura interna	
<b>MEP RATINGS</b> <i>Connessioni</i>	Gas Connection <i>Connessione gas: (3/4") Line</i>  Electrical (wall socket) <i>Collegamento elettrico: 3PH - 380/415 V - 11KW - 16Amp</i>	
<b>COMPLIANCE</b> <i>Conformità</i>	CE	
<b>SAFETY NOTES</b> <i>Aspetti di sicurezza</i>	The oven must be vented in accordance with local and/or national codes <i>Il forno deve ricevere una ventilazione adeguata</i>	
<b>WARRANTY</b> <i>Garanzia</i>	4 Year Structural Guarantee, 12 Months for Gas System & Components <i>4 Anni di garanzia sulla struttura, 12 mesi su tutti i componenti</i>	
<b>MANUFACTURER MATERIALS</b>	Durable high quality ceramic cooking surface, structurally reinforced to ensure the internal pot will not need replacement. Materials fully insulated and housed in steel external finish <i>Superficie di cottura ad alta resistenza e durabilità nel tempo, rinforzata strutturalmente per garantire che la bolla interna sia garantita a vita. Materiali completamente isolati e racchiusi da una struttura esterna in acciaio.</i>	



#### STANDARD FEATURES & OPTIONS

- Durable ceramic cooking surface, no need to replace the internal cooking pot, no downtime in the kitchen.
- Traditional mineral cooking surface, easy adhesion for naan.
- Structurally reinforced for longevity.
- Insulated with high quality thermal materials to improve energy efficiency and heat retention.
- Concealed gas system under unit, away from operator.
- Large 530mm diameter internal cooking barrel.
- 10 piece tool kit: spears, scraper, bread hook.
- Easy installation or relocation.
- Various external shapes and façade cladding options available

#### CARATTERISTICHE & OPZIONI

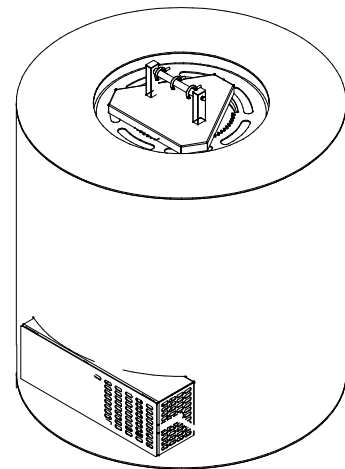
- Superficie di cottura in ceramica resistente, nessuna necessità di sostituire la bolla interna.
- Superficie di cottura adatta ad una facile adesione per il pane Naan
- Strutturalmente rinforzato per una durata infinita della bolla interna
- Isolante di alta qualità per garantire il massimo della sicurezza per l'operatore e la ritenzione del calore
- Impianto Gas/Elettrico posto sotto all'unità
- 530mm il diametro della bolla interna.
- Kit 10: Spiedi, gancio, spatola
- Facile installazione e movimentazione
- Varie opzioni di rivestimento esterno / colore

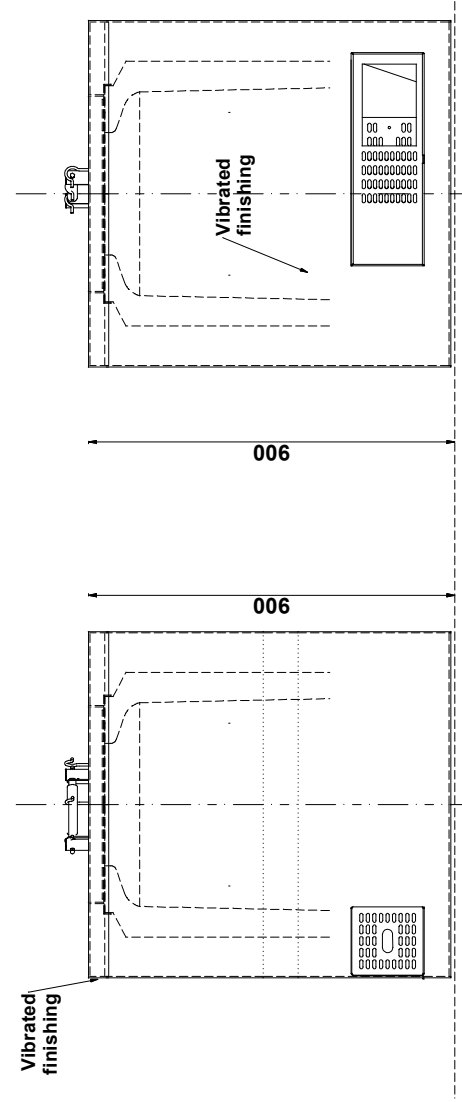
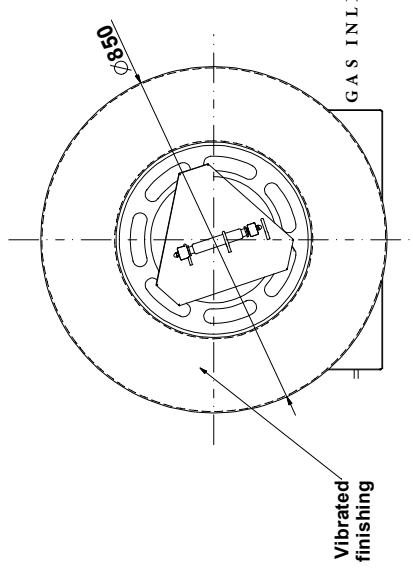
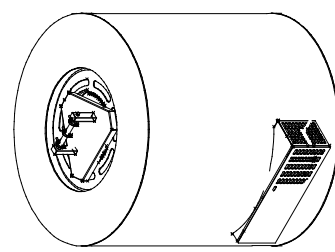

<p><b>ATTENZIONE</b>          THE INFORMATION CONTAINED HEREIN IS THE PROPERTY OF PHOENIX PRIME FOCUS. IT IS TO BE USED ONLY FOR THE PURPOSES SPECIFIED IN THE TITLE OF THIS DOCUMENT. ALL RIGHTS ARE RESERVED. IT IS PROHIBITED TO REPRODUCE OR TRANSMIT THIS DOCUMENT IN ANY FORM OR BY ANY MEANS, ELECTRONIC OR MECHANICAL, INCLUDING PHOTOCOPYING, RECORDING, OR BY ANY INFORMATION STORAGE AND RETRIEVAL SYSTEM. PHOENIX PRIME FOCUS SHALL NOT BE LIABLE FOR ANY DAMAGES, INCLUDING CONSEQUENTIAL DAMAGES, ARISING FROM THE USE OF THIS DOCUMENT.</p>	<p>DATA SHEET Scheda Tecnica</p> <p>TANDOORI ROUND Tandoori Rotondo</p> <p>GAS VERSION Version Gas</p> <p>850x900h</p> <p>Revisione: 000      Date: 26.08.2021</p>	<p>fulvio.leschiutta@phoenixfocus.it</p> <p><b>NOTES:</b></p> <p>1- IN TUTTI I CASI IL CLIENTE DEVE LEGGERE ATTENTAMENTE LE NOTE          2- I DATI E LE DIMENSIONI SONO IN UNITS SI          3- I DATI E LE DIMENSIONI SONO IN UNITS SI          4- I DATI E LE DIMENSIONI SONO IN UNITS SI          5- I DATI E LE DIMENSIONI SONO IN UNITS SI          6- I DATI E LE DIMENSIONI SONO IN UNITS SI          7- I DATI E LE DIMENSIONI SONO IN UNITS SI          8- I DATI E LE DIMENSIONI SONO IN UNITS SI          9- I DATI E LE DIMENSIONI SONO IN UNITS SI          10- I DATI E LE DIMENSIONI SONO IN UNITS SI</p>	<p><b>A</b> STATUS</p> <p><b>B</b> &gt; Approved without notes</p> <p><b>C</b> &gt; Approved with notes</p> <p>&gt; Not compliant</p> <p>Date: _____</p> <p>Signature: _____</p>	<p>PHOENIX S.r.l. Via Risi, 5 33080 - Zoppola (PN) - Italia Tel.: +39 3475135641 fulvio.leschiutta@phoenixfocus.it Tel. +61 468 424 789 rhyannon@phoenixfocus.it</p>	 <p><b>PHOENIX</b> PRIME FOCUS</p>
<div style="display: flex; justify-content: space-between;"> <div style="width: 45%;">  </div> <div style="width: 45%;">  </div> </div> <div style="margin-top: 20px; display: flex; justify-content: center;">  </div> <div style="margin-top: 20px; text-align: right;"> <p><b>Gas version</b> 70mJ ( 66.347 BTU - 19.4KW )</p>  </div>					

<p><b>CONFORME</b>          THE REQUIREMENTS OF THE EUROPEAN DIRECTIVE IN THE AREA OF          ELECTROMAGNETIC COMPATIBILITY (EMC) AND THE EUROPEAN DIRECTIVE          ON THE REDUCTION OF THE RISK OF ACCIDENTS AND DAMAGE TO THE          BODY CAUSED BY ELECTRIC SHOCKS (LVD).</p>	<p>DATA SHEET Scheda Tecnica</p> <p>TANDOORI ROUND Tandoori Rotondo</p> <p>ELECTRIC VERSION Versione Elettrica</p> <p>850x900h</p> <p>Revisione: 000      Date: 26.08.2021</p>	<p>fulvio.leschiutta@phoenixfocus.it</p> <p><b>NOTES:</b></p> <p>1) - QUANTITÀ IN ORDINE SUPERIORE A QUELLA INDICATA IN QUESTA          SCHEDA TECNICA, IL CLIENTE DEVE SPECIFICARE LA QUANTITÀ          IN UNO DEI CAMPI DI COMMENTO. IL CLIENTE DEVE SPECIFICARE          IL TIPO DI FINITURA PER IL TANDOORI. IL CLIENTE DEVE          SPECIFICARE IL TIPO DI CORDONE PER IL TANDOORI. IL CLIENTE          DEVE SPECIFICARE IL TIPO DI CORDONE PER IL TANDOORI. IL          CLIENTE DEVE SPECIFICARE IL TIPO DI CORDONE PER IL          TANDOORI. IL CLIENTE DEVE SPECIFICARE IL TIPO DI          CORDONE PER IL TANDOORI. IL CLIENTE DEVE SPECIFICARE          IL TIPO DI CORDONE PER IL TANDOORI. IL CLIENTE DEVE          SPECIFICARE IL TIPO DI CORDONE PER IL TANDOORI.</p>	<table border="1" style="width: 100%; border-collapse: collapse;"> <tr> <td style="width: 20px; text-align: center;"><b>A</b></td> <td>STATUS</td> </tr> <tr> <td style="width: 20px; text-align: center;"><b>B</b></td> <td>&gt; Approved without notes</td> </tr> <tr> <td style="width: 20px; text-align: center;"><b>C</b></td> <td>&gt; Approved with notes</td> </tr> <tr> <td colspan="2" style="text-align: center;">&gt; Not compliant</td> </tr> <tr> <td colspan="2">Date:</td> </tr> <tr> <td colspan="2">Signature:</td> </tr> </table> <p style="font-size: 8px;">             PHOENIX S.r.l.              Via Riva, 5              33080 - Zoppola (PN) - Italia              Tel.: +39 3475135641              fulvio.leschiutta@phoenixfocus.it              Tel. +61 468 424 789              rhyannon@phoenixfocus.it         </p>	<b>A</b>	STATUS	<b>B</b>	> Approved without notes	<b>C</b>	> Approved with notes	> Not compliant		Date:		Signature:	
<b>A</b>	STATUS														
<b>B</b>	> Approved without notes														
<b>C</b>	> Approved with notes														
> Not compliant															
Date:															
Signature:															

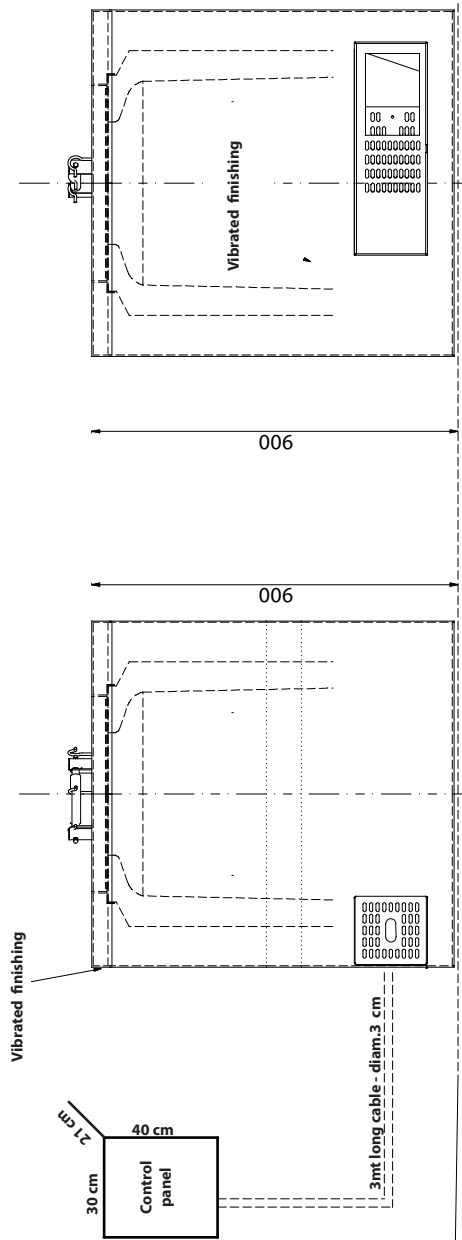

006

850

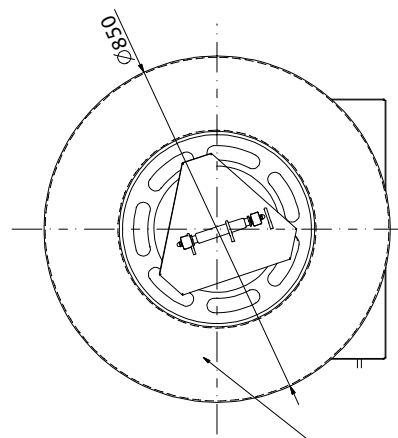

Ø850

Vibrated finishing

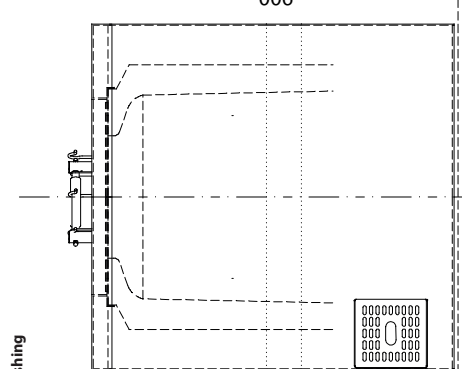

006

850

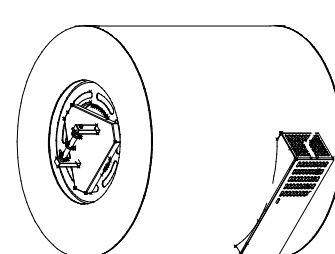

Vibrated finishing

Electric version  
3PH - 380/415 V - 11KW



<p><b>CONFORME</b>          THE REQUIREMENTS OF THE EUROPEAN DIRECTIVE IN THE AREA OF ELECTROMAGNETIC COMPATIBILITY (EMC) AND THE REQUIREMENTS OF THE EUROPEAN DIRECTIVE ON THE REDUCTION OF THE RISK OF ACCIDENTS BY MACHINERY (Machinery Directive) AND THE EUROPEAN DIRECTIVE ON THE REDUCTION OF THE RISK OF ACCIDENTS BY MACHINERY (Machinery Directive)</p>	<p>DATA SHEET Scheda Tecnica</p> <p>TANDOORI ROUND Tandoori Rotondo</p> <p>CHARCOAL VERSION Versione Carbone</p> <p>850x900h</p> <p>Revisione: 000      Date: 26.08.2021</p>	<p>fulvio.leschiutta@phoenixfocus.it</p> <p><b>NOTES:</b></p> <p>1) -&gt; APPROVED WITH NOTES          2) -&gt; APPROVED WITHOUT NOTES          3) -&gt; NOT COMPLIANT</p>	<p><b>A</b> STATUS</p> <p><b>B</b> &gt; Approved without notes</p> <p><b>C</b> &gt; Approved with notes</p> <p>&gt; Not compliant</p> <p>Date: _____</p> <p>Signature: _____</p> <p>PHOENIX S.r.l. Via Risi, 5 33080 - Zoppola (PN) - Italia Tel.: +39 3475135641 fulvio.leschiutta@phoenixfocus.it Tel. +61 468 424 789 rhyannon@phoenixfocus.it</p>
