

Manufacturer	Phoenix Prime Focus, Australia	
Model No.	DK900JC	
Description	Round Duck Oven with Stone Hearth Floor	
Purpose	Oven used to cook Peking Duck, Char Sui Pork, other Meats and Dishes	
Fuel Options	Full Gas, Combination Gas & Wood	
Gas Requirements	70mj (66,650 Btu) Thermostatically Controlled Infinity Gas Display Burner	
Exhaust Requirements	Under Canopy/Hood or Direct Connect via Phoenix Flue Transition with Particle Filter and fitted with Thermal Interlock Sensor, to a grease rated exhaust fitted with a suitable power fan (supplied by others) <i>The exhaust is best in a dedicated system. It is critical that ductwork be installed in accordance with local regulations.</i>	
External Dimensions	1250mm (Diameter) x 1888mm (H)	Oven Weight (Approx.) 1400kg
Internal Dimensions	900mm Diameter	
MEP Ratings	Gas Connection: 19mm (3/4") Line Electrical (wall socket): 230-240V (Single Phase) 10amp	Exhaust Connection: 300mm x 300mm Universal Duct. 700L/s. 150 Pa
Compliance	The oven and gas system are CE & AGA compliant	
Warranty	4 Year Structural Guarantee, 12 Months for Gas System & Components	
Safety Notes	The oven must be vented in accordance with local and/or national codes All gas systems fitted with flame failure, thermal interlock sensor and pressure differential switch for safety Oven facade/enclosure is to be constructed from non-combustible (fire-rated) materials Ventilated access panels required both above and below the oven (min. size 600mm x 600mm)	
Manufacturer Materials	High quality ceramic materials fully enclosed in a 5mm mild steel external shell. One piece cast ceramic ceiling. The cooking surface is constructed using high quality ceramic alumina bricks	

STANDARD FEATURES & OPTIONS

- Thermostatically controlled gas system with easy to use compact digital temperature control panel, remote mount option available.
- Unique exhaust design with advanced safety features.
- Traditional style fire grate for oven mouth.
- Accessory Kit: removable SS drip tray, hooks and tool set.
- 1 Piece Stainless Steel Hearth and Lintel surround for oven mouth. Easy and safe integration with architectural facade.
- 2 Part assembly for easy installation. All ovens can be designed for transport through doorways, lifts & staircases.
(Please advise prior to order as alteration may be required)
- Internal Spotlight included as a standard feature.
- Flue transition with flame resistant particle filter.
- Optional extras available: viewing window.
- Various facades and external cladding options.

Approx. 6 DUCK CAPACITY

Cooking Time 50 - 60 mins (based on oven operating at 325° C)

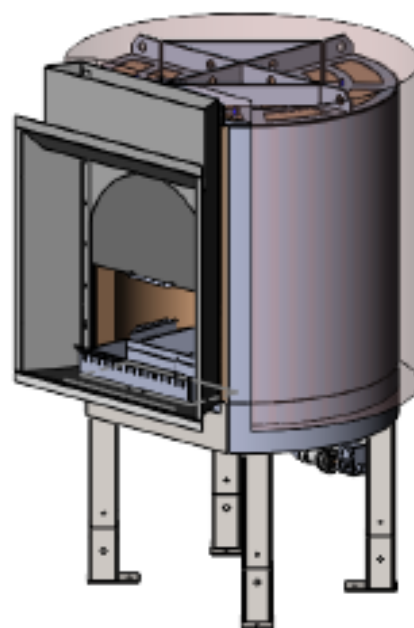

Sample image only, details and finishes may vary. Refer to technical drawing over.

SLIDING DOOR

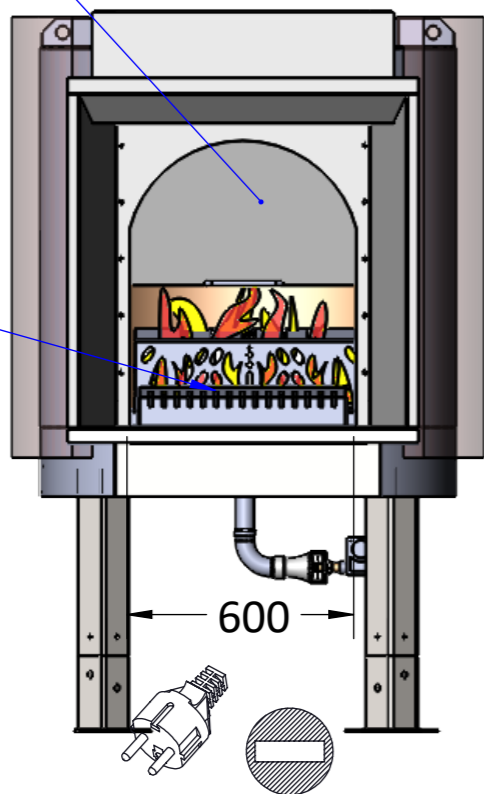

FIREGRATE & DRIPTRAYS

RAILS

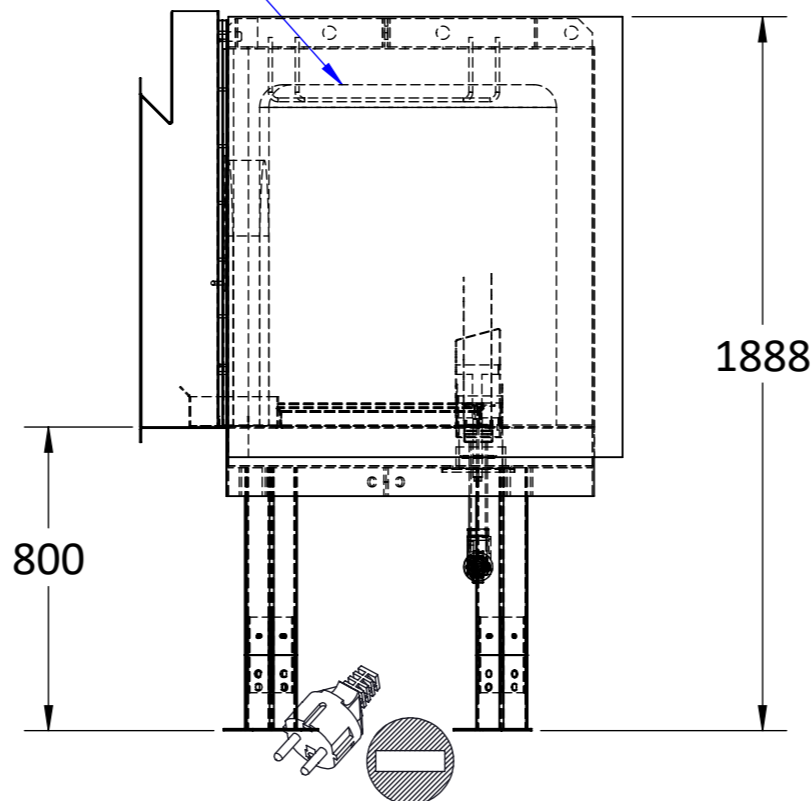

OVEN MASS:
TOP SECTION: ~865kgs.
BASE SECTION: ~430kgs.

FEATURES:
AUTOMATIC GAS SYSTEM
DRIP TRAYS & FIREGRATE
3 x HANGING RAILS (<12 DUCK)
EXHAUST OPTION FOR CANOPY
INTERNAL OVEN LIGHT.

R550(STEEL)

R625(O/ALL)

R550(ID)

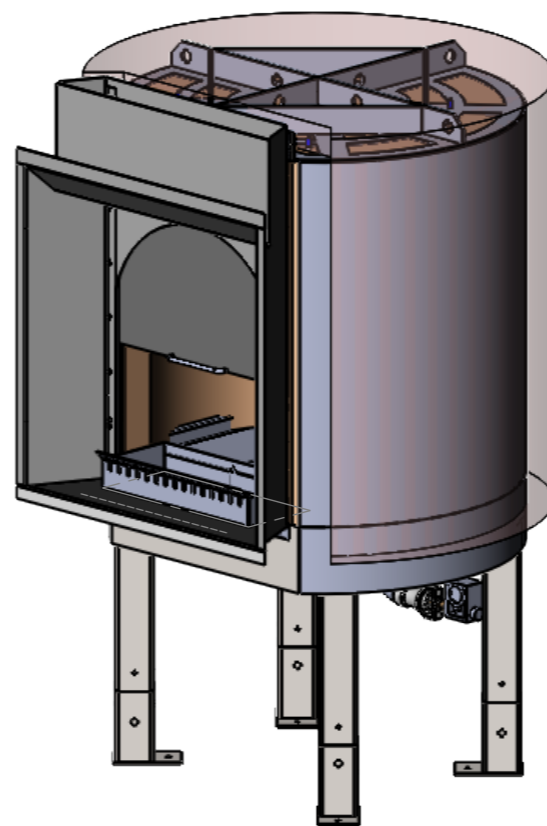
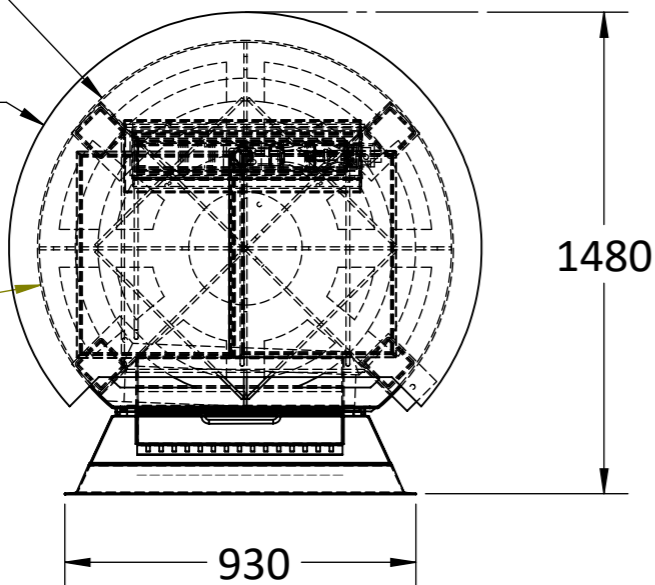

OVERALL DIMENSION INCLUDES 50mm INSULATION +25mm AIR GAP

OFF.N°	2017-....
--------	-----------

REFERENCE	SPECIFICATION SHEET DK900JC
-----------	--------------------------------

DESIGNER	
----------	--

COPYRIGHT
THE INFORMATION CONTAINED IN THIS DRAWING IS THE SOLE PROPERTY OF PHOENIX PRIME FOCUS PTY LTD. ANY REPRODUCTION IN PART OR AS A WHOLE WITHOUT THE WRITTEN PERMISSION OF PHOENIX PRIME FOCUS PTY LTD IS PROHIBITED.

Revision > 000	Date: 31-08-2017
----------------	---------------------

Revision > 001	Date:
----------------	-------

Revision > 002	Date:
----------------	-------

ORDER	-
-------	---

DATE ORDER	-
------------	---

NOTES:	
--------	--

STATUS	
--------	--

A	> Approved without notes
---	--------------------------

B	> Approved with notes
---	-----------------------

C	> Not compliant
---	-----------------

Date:	
-------	--

Signature:	
------------	--

greg thomson
+61 458 772 253
sales@phoenixfocus.com.au

SERVICES LEGEND.	
SYMBOL	SERVICE
	220/240V Single phase 10amp Wall socket req'd.
	Gas connection: Total 70mJ. (Nat.) (gas type tbd.)
	EXHAUST CONNECTION: Recomend CANOPY: opt.by request.

BRISBANE AUSTRALIA
PO BOX 1258
SPRING HILL

